

Oil leakage into air cleaner

Model: Fiesta 2001+

Summary: Inadequate oil return within the valve cover in conjunction with high levels of crankcase exhaust gases can lead to engine oil leakage into the air cleaner housing via the positive crankcase ventilation hose connected to the valve cover. Engine oil leakage from the air cleaner housing is expressed by the customer as a concern regarding loss of engine oil. It may at times lead to blue-smoke emission.

If a concern is expressed, a 0.8mm hole must be drilled in the intermediate wall of the valve cover. This results in a reduction of the air flow speed within the valve cover, preventing the engine oil from penetrating into the air cleaner housing via the valve cover.

Parts Required

Description	Finis	Quantity
Air cleaner housing with air cleaner element, 1.3L Duratec-8V (Rocam) engine	1 435 360	1
Air cleaner element, 1.3L Duratec-8V (Rocam) engine	1 140 778	1
Air cleaner element, 1.6L Duratec-8V (Rocam) engine	1 089 896	1
Positive crankcase ventilation filter, 1.3L Duratec-8V (Rocam) engine	1 148 112	1
Positive crankcase ventilation filter, 1.6L Duratec-8V (Rocam) engine	1 045 142	1

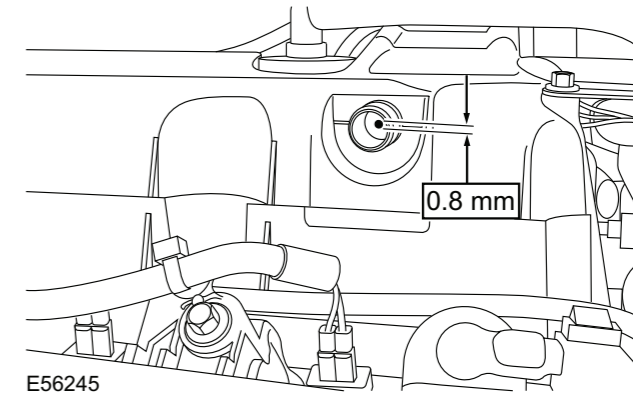
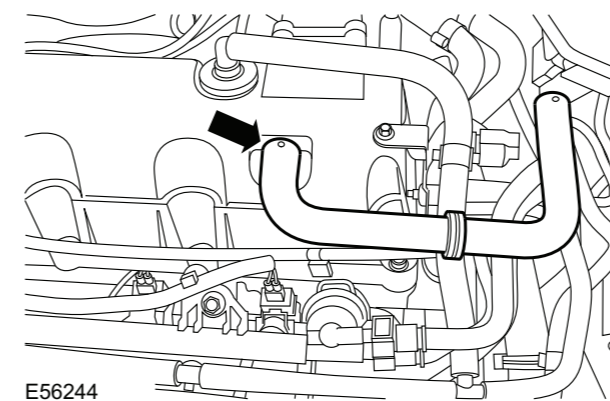

E56245

1. Remove the air cleaner.
2. Disconnect the positive crankcase ventilation hose from the valve cover.
3. **NOTE:** Plastic residue resulting from drilling the hole will not adversely affect vehicle performance and does not need to be removed from the valve cover cavity.
 - Drill a 0.8mm hole in the intermediate wall of the valve cover through the positive crankcase ventilation hose union.
4. **NOTE:** Only install a new air cleaner element housing if the contamination is attributable to engine oil leakage via the positive crankcase ventilation hose.
 - Check the air cleaner element and positive crankcase ventilation filter for oil residue contamination; replace if necessary (see "Parts Required"). Check the air cleaner housing for oil residue contamination. Air cleaner housings contaminated with engine oil cannot be cleaned and a new housing must be installed (see "Parts Required").
5. Install the components.



Ford Fiesta – Engine/Steering

Your Technical Supplement 14

FordParts

Feel the difference



Noise from steering assembly

Model: Fiesta 1996 - 2000

Summary: Should a customer express a concern over noise coming from the steering, the following procedure should be followed. There are several different areas to be looked at on the steering column, any of which could be the source of the noise.

Parts Required

Description	Finis	Quantity
Instrument panel fixing screw	6 866 813	1
Clockspring	1 018 554	1
Tape Insulation, Black	Locally procured	1
Squeak and rattle repair kit - FSE Order Number	317 1205 001 00	1

Root cause diagnosis

A series of checks must be carried out to determine the root cause of the steering noise. The noise could be caused by several possible concerns, these are:

- A.** Lack of lubrication of the lower steering seal to upper steering seal.
- B.** Insufficient grease applied at the steering wheel clockspring for the multifunction horn contact pins or broken clockspring.
- C.** Shaft of driver's airbag fixing screw touching steering wheel housing.
- D.** A possible touch condition between the fixing bolt on the lower steering column shroud.

Repair procedure

The following is the repair procedure detailing each repair process. The application of grease to the lower steering seal MUST be carried out before any of the other operations. If this cures the noise then no further work needs to be carried out. The procedures must be followed in sequence until the noise is no longer apparent. It will not be necessary in all cases to carry out all procedures.

A. Insufficient lubrication of the coupling at the base of the steering column

1. Access the coupling at the base of the lower steering column.

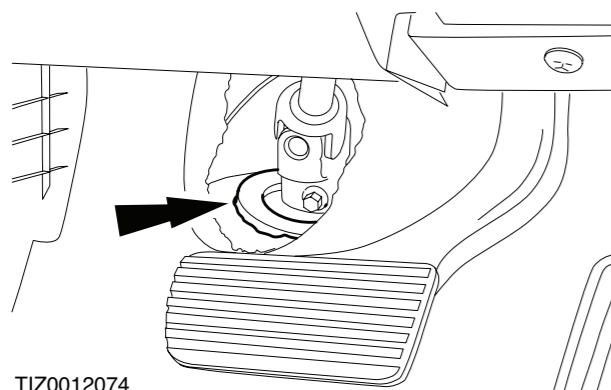

TIZ0012074

2. Apply grease from repair kit (see Parts Required) to the lower column sealer at the dash panel.
3. Test for noise by turning the steering wheel in both directions.
 - If the noise is still present, go to next step.
 - If the noise is no longer present, no further action is required.

B. Insufficient grease applied at the steering wheel clockspring for the multifunction contact pins or broken clockspring

1. Disconnect the battery ground cable.
2. Remove the steering wheel.
3. Make sure that the clockspring and contact pins are sufficiently greased (see Parts Required).
4. Rotate the clockspring in both directions to check for noise.
 - If the clockspring is noisy or damaged, go to next step.
 - If the clockspring is NOT damaged, go to step 9.

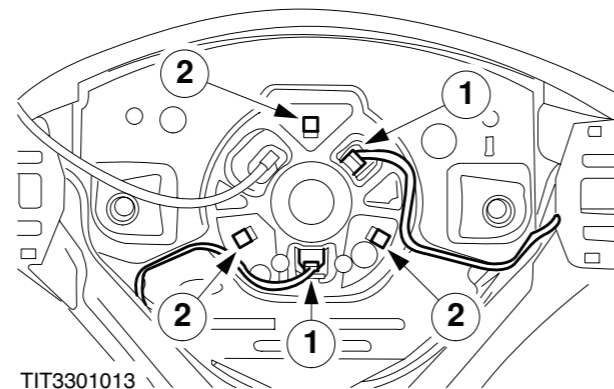

TIT3301013

5. Detach the airbag sliding contact.
 1. Disconnect the electrical connectors.
 2. Release the retaining tangs.

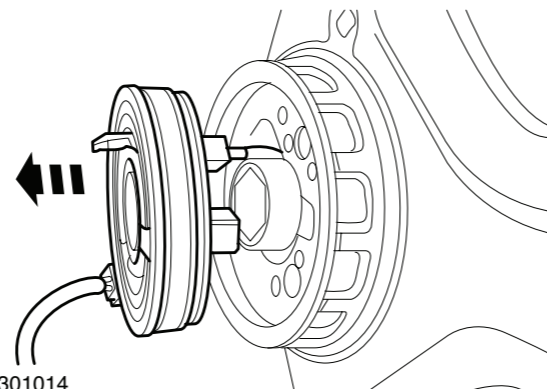

TIT3301014

6. Remove the air bag sliding contact and remove the clockspring.
7. Install new clockspring (see Parts Required).

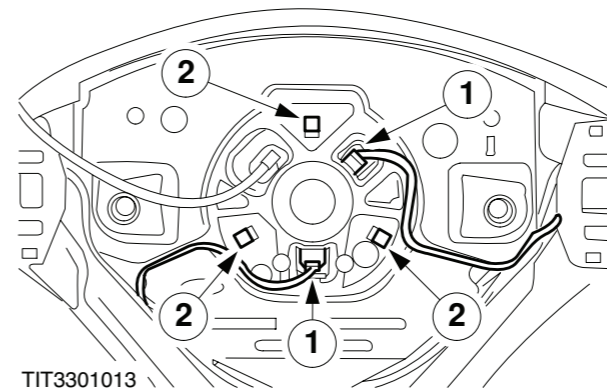

TIT3301013

8. Install the airbag sliding contact.
 1. Connect the electrical connectors.
 2. Check the retaining tangs have engaged.

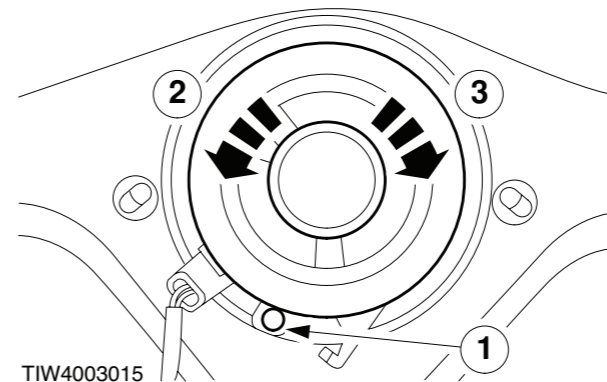

TIW4003015

9. WARNINGS:

- » The sliding contact centralising procedure MUST be carried out before installing the sliding contact.
- » If there is any doubt about the centralising of the air bag sliding contact, the centralisation procedure must be repeated.

Centralise the clockspring

3. Depress the locking pin.
 4. Rotate the inner rotor against the outer rotor fully counterclockwise.
 5. Rotate the inner rotor clockwise approximately 3¾ turns. Release the locking pin, make sure that the inner rotor is locked in position.
10. Thoroughly grease (see Parts Required) the sliding contacts.

C. A touch condition of the drivers air bag fixing screws

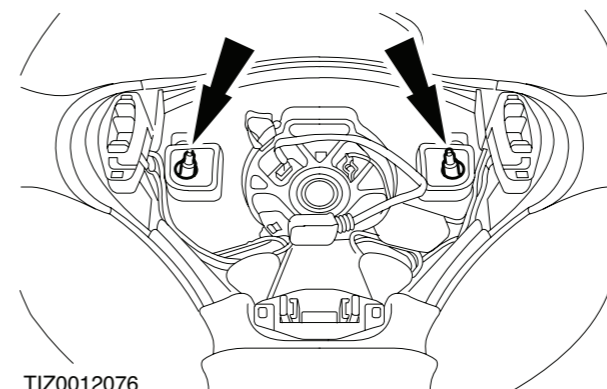

TIZ0012076

1. Access the airbag fixing bolts.
2. Apply tape (see Parts Required) around the airbag fixing bolts.

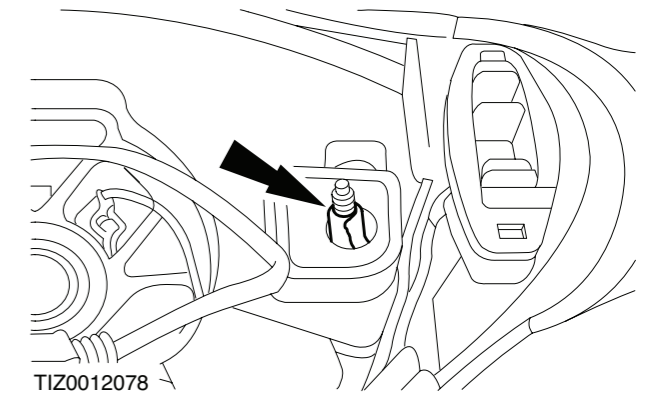

TIZ0012078

3. **NOTE:** Do not install the steering column shroud
 - Install the steering wheel.

D. Touch condition of speed nut for fixing lower steering column

1. Turn the speed nut 90°
 - Make sure that the speed nut is NOT in contact with the instrument panel fixing screw.

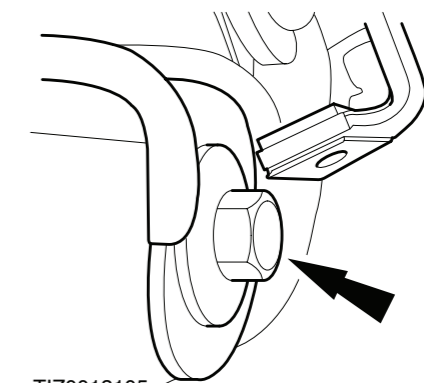

TIZ0012105

2. Remove existing instrument panel fixing screw and install new instrument panel fixing screw (see Parts Required).

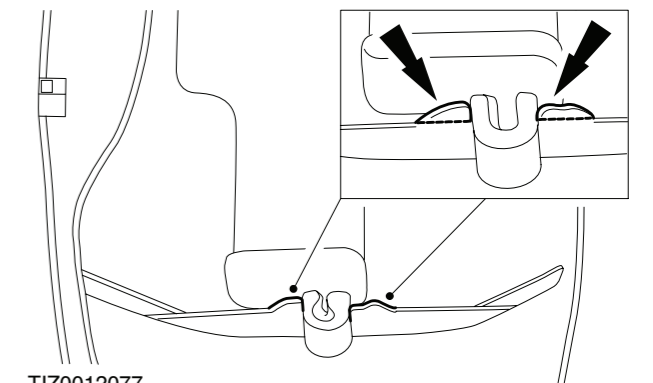

TIZ0012077

3. Rework the shroud by carefully cutting off the reinforcement ribs.
4. Install the shroud and check for touch condition.